

# THE HOLLOW STATE NEWSLETTER

Dallas Lankford, Editor  
P. O. Box 6145  
Ruston, LA 71272-0018

Number 29

Ralph Sanserino, Publisher  
12072 Elk Blvd.  
Riverside, CA 92505 -3835

---

**SUBSCRIPTIONS:** \$5 for 4 issues, nominally 3 or 4 issues per year.

**BACK ISSUES:** \$1.25 each, all issues currently available.

**SELECTED REPRINTS:** The best of *The Hollow State Newsletter* from numbers 1-4, \$1.25

**PAYMENT:** Send check or money order payable to Ralph Sanserino, address above. Prices apply to the U.S.A., Canada, and Mexico. Double quoted prices to other areas. Checks and money orders must be in U.S.A. funds payable in U.S.A. clearing house format.

---

All submissions for possible publication in *HSN* should be sent to Dallas at his address above. The editor and publisher assume no responsibility for the accuracy or safety of untested modifications or the reliability of suppliers of services, parts, or equipment mentioned in *HSN*.

---

## Editor's And Publisher's Corner

Excuse me for the long delay in getting out HSN # 29. Last year was a very bad year for me, beginning with a two month ordeal in April for what should have been a simple CA/CH replacement, and ending with gum surgery followed by a bad virus in December.

Please note Ralph's new address above (below the masthead).

Ralph and I are still planning to fold up HSN with issue # 30 unless someone volunteers to take over editing and publishing. Actually, we need two volunteers because it is unlikely that anyone would want to do both. Any takers? If not, we will cease publication with the next issue, and refund all remaining subscriptions.

This issue is devoted to R-390A alignment. If you are already experienced with R-390A's, then these notes alone should suffice. If not, you should supplement these notes with one or more of the R-390A maintenance manuals TM 11-956A, TM 11-5820-358-35, and NAVSHIPS 0967-063-2010 (or NAVSHIPS 93053 Vols I, II, III).

Many months ago Ralph sent me a list of equipment he has for sale. Because of the long delay in writing up HSN # 29, I expect some of the equipment has been sold. Nevertheless, here is a list: R-390A, HQ-180C, 422 scope, new URM-25D signal generator, Pro-2005 scanner, Central Electronics sideband slicer, Central Electronics Q-multiplier model DQ, Radio Shack DX-440 multi-band portable with MW loop, misc. R-390A parts, R-392, R-392 parts (tubes, IF deck, etc.), BC221 frequency meter, URM-32A frequency meter, Heathkit SB620 scanalyzer, Hammarlund HC-10. Write Ralph at his new address above for details, and be sure to include an SASE.

Dallas left some room for me. I will stay on as publisher for awhile and i think we may have an editor, Reid Wheeler of Olympia WA may do the editing job. We are going to need help from the membership if HSN is going to hang in there. We need articles and stuff on tube gear. So lets hear from you out there.....73.....Ralph.....

R-390A Alignment, Dallas Lankford, January 1993

Before aligning R-390A tuned circuits, alignment of the Veeder Root counter, cams, RF bandswitch gears, antenna trimmer, and PTO should be inspected, and, if necessary, realigned.

To determine if the Veeder Root counter (the MCS/KCS counter; see Fig. 1) is aligned (1) turn the ZERO ADJ knob clockwise until the clutch is disengaged, i.e., until the digit wheel of the Veeder Root counter does not move when the KCS knob is turned through its zero adjust range (about 14 KHz), (2) set the KCS knob at about the center of its zero adjust range, and (3) turn the ZERO ADJ knob fully counter clockwise to engage the clutch. The KCS knob should be left in the center of its zero adjust range for the remaining checks and alignments. Next, (4) turn the KCS knob throughout its entire range, from one limit of the 10 turn stop to the other. An aligned Veeder Root counter should read about xx-965 and xx+035 at the stop limits. In other words, the 1000 KHz tuning range of an R-390A has about 70 KHz of over range, and the over range should be divided equally between the two ends of the 1000 KHz tuning range.

When an R-390A is tuned to 07+000 the cam tips should align with the lines on the front plate of the RF subchassis as shown in Fig. 2.

The RF bandswitch gears should also align as shown in Fig. 2.

If the Veeder Root counter reads within 3 or 4 KHz of xx-965 and xx+035 at the stops, and the cams align within 3 or 4 KHz of 07+000, then they need not be realigned. But if they are off more than 3 or 4 KHz, then you should consider realigning them.

loosen spline set screws on non-mar clamps of BFO and BANDWIDTH shafts and push shafts through front panel

loosen DIAL LOCK mechanism nut (behind knob) and rotate mechanism to clear metal disc (behind front panel)

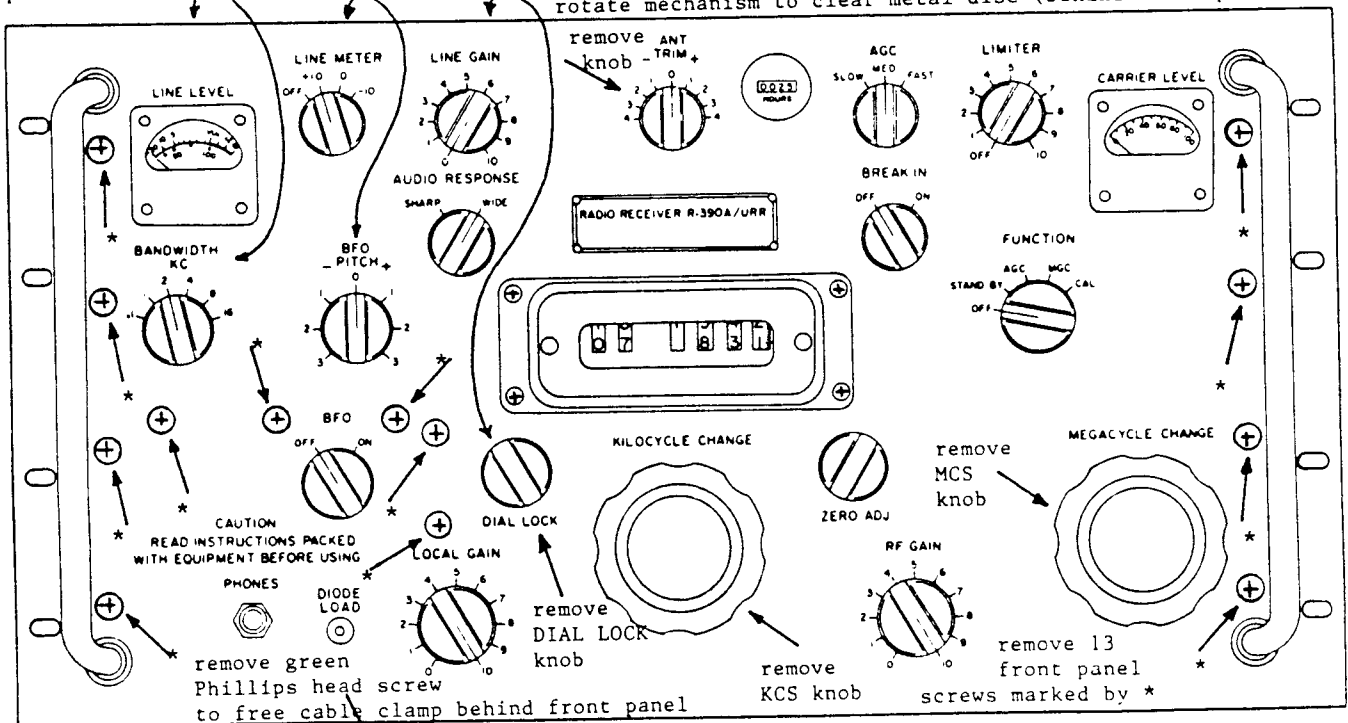

FIG. 1 Front Panel Removal

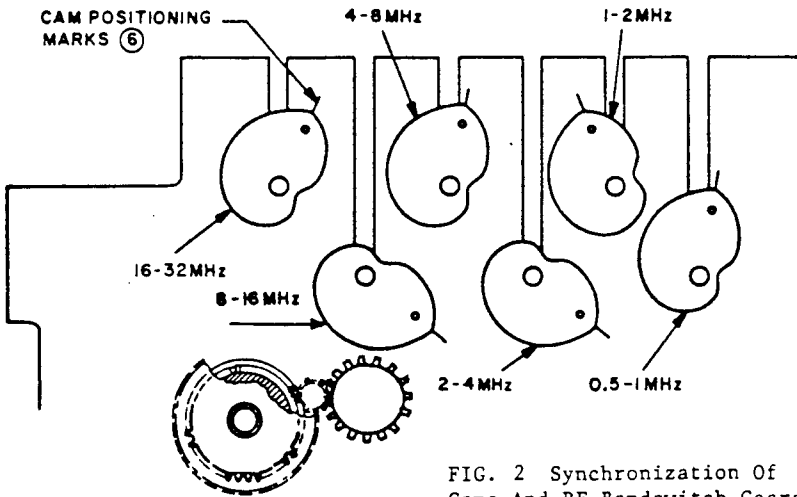

FIG. 2 Synchronization Of Cams And RF Bandswitch Gears, Frequency Set At 7+000

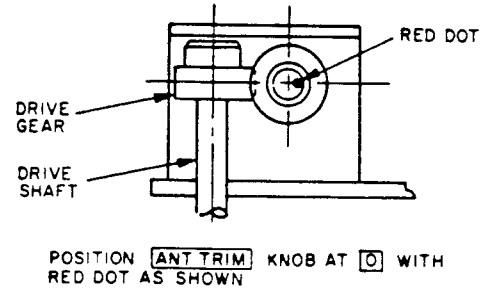

FIG. 3 Synchronization Of ANT TRIM

The Veeder Root counter and cams alignments are interrelated. Changing the alignment of the Veeder Root counter changes the alignment of the cams, and vice versa. Also, each cam can be aligned independently of the other cams by loosening the non-mar clamp on the gear in front of the cam.

Because the Veeder Root counter and cams alignments are both dependent and independent, there are many ways they could have gotten out of alignment, and thus it is difficult to specify all ways to realign them. Nevertheless, here is a generic realignment of the counter and cams which should work in most cases.

If all of the cam tips align at the same frequency, and the difference between the cam tips alignment and 07+ stop is about 35 KHz (example: cam tips align at 07+015 and 07+ stop is at 07+050), then loosen the non-mar clamp on the right side bevel gear of the Veeder Root counter, and reset the digit drum of the counter to read 07+035 with the KCS knob at the 07+ stop. The bevel gear can be accessed by removing the counter cover plate which is attached to the front panel by 4 Phillips head screws; see Fig. 1. After tightening the non-mar clamp on the bevel gear, turn the KCS knob through its range to make sure that the bevel gear is not binding and that there is no backlash in the digit drum. If there is binding or backlash, loosen the non-mar clamp, reposition the bevel gear, tighten the clamp, and check for binding or backlash again. Repeat until binding and backlash are eliminated or minimized.

If all of the cam tips do not align at the same frequency, remove the front panel (see Fig. 1), set the KCS knob to the 07+ stop, align the Veeder Root counter to 07+035, set the KCS knob to 07+000, and for each cam loosen the non-mar clamp on the gear in front of the cam, set the cam tip to its alignment line, and tighten the non-mar clamp. It may be necessary to remove the associated rack tension springs when aligning a cam tip.

If all of the cam tips align at the same frequency, but the frequency difference between cam tip alignment and 07+ stop is not 35 KHz, then you can either realign the counter and cams as described above, or pull the gear on the KCS shaft and reposition it so that the frequency difference is 35 KHz (be sure to observe the amount of tension on the split gear before removing it, and reinstall it with the same amount of tension).

The RF bandswitch alignment is also shown in Fig. 2. The 4 teeth on the large gear should point straight down (they can be seen from underneath). The only sure way to determine if an RF bandswitch is out of synchronization and to realign an unsynchronized RF bandswitch is to use a known good RF subchassis for comparison. Both RF subchassis should be removed from their respective R-390A's so that the positions of the bandswitch wafers can be compared as the MCS shaft is turned through its entire range.

Synchronization of the xtal oscillator (attached to the RF subchassis) also requires a known good RF subchassis for comparison. It is unlikely that either the RF bandswitch or xtal osc. will be unsynchronized, and so I have not given many details about how to realign them. In both cases an obvious clamp is loosened, the shaft repositioned, and the clamp tightened. And in both cases several attempts may be needed to get it right.

Alignment of the ANT TRIM is shown in Fig. 3. Two set screws behind the gear drive are loosened to realign the antenna trimmer. Often the red paint of the "red dot" has flaked off, and there is only a small dimple (like a center punch mark) where it was. Do not tighten the set screws too tight, otherwise the bakelite insulation between the gear drive and antenna trimmer shaft may be crushed, which may cause the AGC line to be shorted to ground through R201.

If the PTO end points are aligned (tuning from xx-000 to xx+000 changes the received frequency by exactly 1000 KHz), then the PTO can be synchronized by adjusting the Oldham coupler; see Fig. 4. Before synchronizing the PTO, check the BFO and CAL alignments as follows. Set the BANDWIDTH to 2, FUNCTION to CAL, and tune any calibrator signal so that it is in the center of the filter passband. (For example, suppose that as you tune below the calibrator signal near xx 500, the carrier level meter falls by 10 dB at xx 498.6, and as you tune above it falls by 10 dB at xx 501.2, then the filter center is about  $(498.6 + 501.2) / 2 = xx 499.4$ .) Turn the BFO on, loosen the BFO tuning shaft clamp, and rotate the BFO PTO shaft for zero beat while holding the BFO knob at 0 (12 o'clock). Tighten the BFO shaft clamp. Next, set BANDWIDTH to 16, change the FUNCTION switch to AGC, and zero beat to WWV (5, 10, or 15 MHz, whichever is stronger). Change the FUNCTION switch back to CAL and zero beat by turning the CAL ADJ slot adjustment on the rear panel. If the calibrator will not zero beat, you probably have a defective 200 KHz calibrator xtal (which should be replaced). Set the Veeder Root counter to xx 000. (For example, let's say you

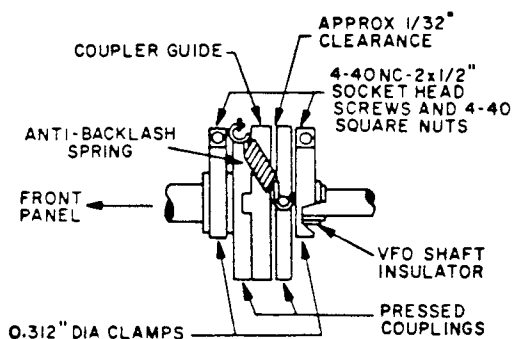

FIG. 4 Oldham Coupler Clearance  
And Details

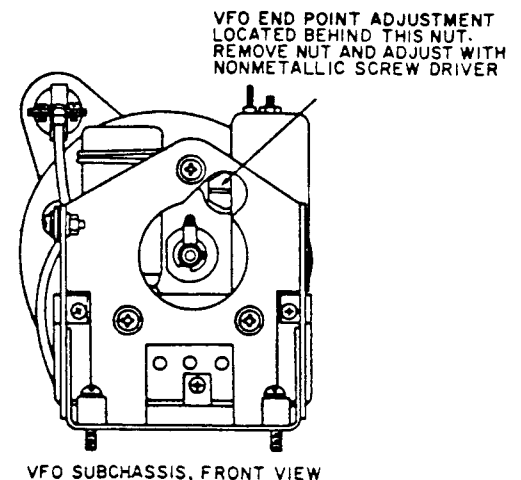

FIG. 5 PTO End Point Adjustment

were tuned to WWV 15, and the counter read 15 003.8. Then you would set the counter to 15 000 and hear a 3.8 KHz het with the BFO.) Loosen the clamp on the front panel side of the Oldham coupler, and turn the Oldham coupler for zero beat while holding the KCS knob to keep the frequency indication at xx 000. Tighten the clamp.

PTO end point alignment for non-Cosmos PTO's has been described in detail in HSN # 6. For Cosmos PTO's, end point alignment is the same, except that the end point adjustment access hole is covered by a screw instead of a slotted hex nut, and the screw is hidden completely behind the inductor shield; see Fig. 5. If the end point alignment of a Cosmos PTO is done with the PTO in place, care should be taken not to make contact with inductor support wires because some of them carry +250 VDC or higher, which can kill you. Usually the end points of a PTO have spread (expanded) so that turning the KCS knob through 1000 KHz changes the received frequency by more than 1000 KHz. In that case, you turn the end point adjustment slug clockwise to bring the range back to 1000 KHz. The exact amount you will need to turn the slotted shaft of the slug depends on the amount of adjustment remaining (i.e., on the position of the slug inside the coil, which you can't see). Try one turn and observe how much the spread is reduced. If the range is reduced to less than 1000 KHz, turn the slug counter clockwise on the next try. After several tries, you should have the range back to 1000 KHz, unless the end point adjustment range has been mostly used up before you started. In that case, if you are adventurous, you can take the PTO apart and remove one turn from the end point adjustment coil. But don't move any wires around inside the inner "can," don't take a turn off the big coil (the main tuning coil), and don't take a turn off the Cosmos "corrector coil." After the end points are aligned, you will need to resynchronize the PTO as described in the previous paragraph above because end point alignment moves both end points.

After having checked the alignment of the Veeder Root counter, cams, RF bandswitch gears, antenna trimmer, and BFO, the R-390A RF tuned circuits can be aligned as follows. Basically, the idea is to use the R-390A xtal calibrator and carrier meter instead of a signal generator and volt meter. Fig. 6 is a line drawing of the RF subchassis Utah-shaped cover plate which already contains most of the information you need. In addition, I have sketched the locations of T207 and T208. Remove the Utah-shaped cover plate, and peak the inductors and trimmers at the frequencies indicated with the FUNCTION switch set in the CAL position. In use the 4 KHz or 8 KHz bandwidth; it doesn't matter which. The order in which you align the coils does not matter. It is good practice to align the inductor first, and then the trimmer. Adjust each inductor and trimmer at least twice. If there is any significant improvement on the second pass, adjust them a third time (or more if necessary). The inductors should be adjusted with a # 8 Bristol multiple spline screwdriver. Xcelite makes a nice set, 99-PS-60, which includes the 99-X5 extension. The ceramic trimmer capacitors may be adjusted with a small screwdriver or alignment tool, but any metal shaft should be insulated (say, with insulating tape) so that you don't ground the high voltage B+ which is present on the metal slot of some of the trimmers. T207 and T208 may be adjusted with a small screwdriver. For best results, the antenna coils T201-T206 should be aligned with a 50 ohm source signal generator connected to the balanced antenna input through a UG-971/U twinax to C connector adapter and a UG-636A/U C to BNC connector adapter. But if you don't have a signal generator, or you are in a rush, you can use the CAL approach for them too. If you align an R-390A which has not been aligned in many years, some of the ceramic trimmers may be nearly "frozen." Firm

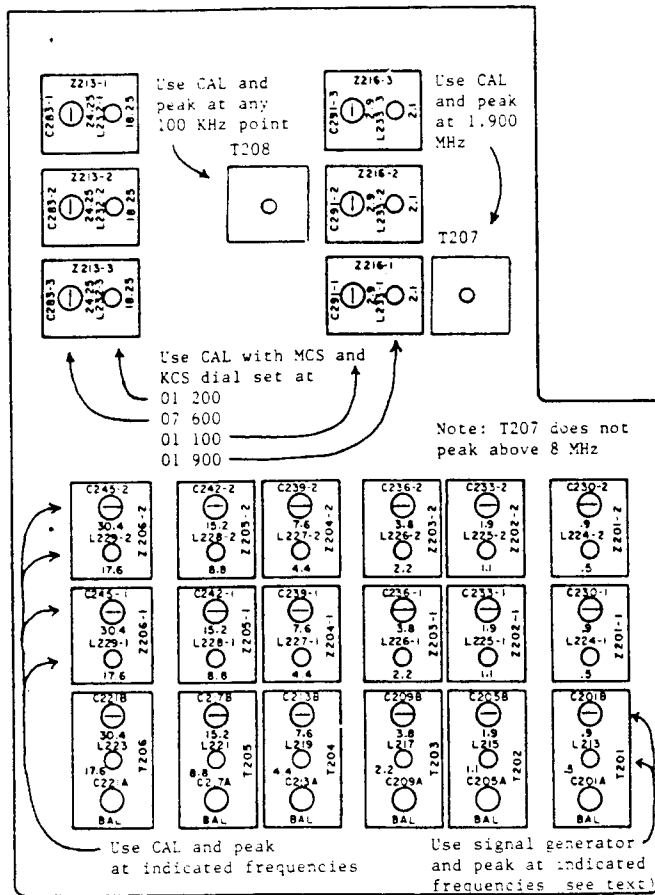

FIG. 6 RF and Variable IF Alignment

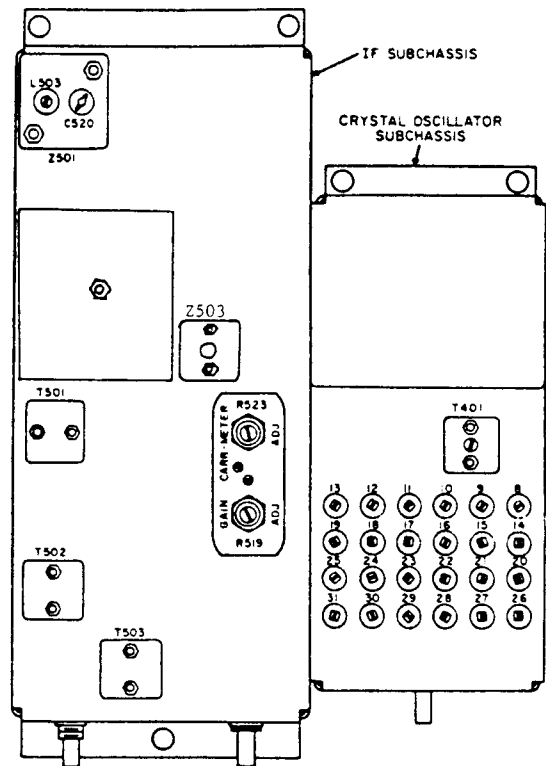

FIG. 7 Xtal-Osc. and IF Alignment

screwdriver torque will usually break them free with an audible "snap." However, if loss of signal level is observed after breaking the trimmer free, you should remove the coil (remove the rack and slugs for that coil set to access the # 4 Phillips head screw at the bottom of the bakelite coil form, and unplug the coil assembly), remove the coil assembly shield, and inspect the underside of the ceramic trimmer assembly to see if the metal base has rotated during "unfreezing" and shorted to one of the metal coil supports.

After the RF subchassis has been aligned, each of the ceramic crystal oscillator trimmers should be peaked. Tune to any CAL signal in the band indicated above the trimmer (see Fig. 7) and peak the signal. Not shown in Fig. 7, eight of the trimmers can be peaked in either of two bands: 0-17, 1-18, 2-19, 3-20, 4-21, 5-22, 6-23, 7-24. After peaking such a trimmer in one band, you do not need to peak it again in the other band. Peak T401 (also marked T207).

Alignment of the IF subchassis is usually unnecessary. But if you insist on aligning it, get yourself a set of TV Alignment Tools from Radio Shack, catalog no. 64-2223. The white hex alignment tool may be used to peak the AGC IF transformer Z503. Do not meddle with the IF transformers T501 - T503. They are stagger tuned, and their peaks are very broad. Even if they are somewhat out of alignment, it will not matter. The red alignment tool with metal tip is suitable for aligning trimmers (provided the metal shaft is insulated to avoid shorting RF trimmers; see above). The mechanical filter trimmers may be accessed by removing the shield on top of the chassis, and disconnecting the shafts to the front panel knobs, releasing the green quick release screws, and tilting the IF subchassis up far enough to access the trimmer holes in the side of the chassis. I'll let you discover for yourself which trimmer peaks which filter. Don't mess

with the crystal filter inductor L503 or trimmer C520 unless you have to replace the 455 KHz xtal, and then consult the manual for alignment. The IF gain may be adjusted by R519, a slot adjust pot with lock nut. The manual provides detailed instructions for setting the pot. My approach is to set the IF gain for minimum, i.e., the slot adjust is rotated fully clockwise. However, in one R-390A the IF gain adjust pot was marked 10K (correct), but measured 20K (incorrect) at minimum gain (maximum resistance). So I always measure the resistance of the IF gain adjust pot to be sure it is about 10K when the slot adjust is fully clockwise. Some of these 10K pots measure a bit less, say 8.5K, which is OK. Just don't go over 10K. The carrier meter zero adjust R523 is the only flakey feature on an R-390A. It is virtually impossible to zero a carrier meter with R523, and even if you do succeed in zeroing a meter (with no signal), the meter will not hold zero (because the pot wiper setting is so critical). There is only one solution to this problem. Replace R523 with a 10 turn pot, Clarostat 73JA 100 ohm 2 watt wire wound. Instead of reusing the original 22 ohm 1 watt R537 which shunts the original R523, or trying to locate another 22 ohm 1 watt resistor (with leads which are too large to use effectively with a 73AJ), get a 10 ohm 1 watt resistor at Radio Shack, catalog # 272-151 (it has smaller leads), and use it. After doing this mod, before turning on your R-390A and pinning the carrier meter while you are setting the meter zero, adjust the shunted pot to about 5 ohms (the nominal value for meter zero). The 73JA usually does not insert easily unless you use a circular file to remove a small amount of metal from the rim of the pot mounting hole. And the 73JA usually does not mount well unless you grind a nut thinner and run the thin nut all the way down on the pot threads (the diameter of the pot mounting base is too small). A nice finishing touch is to use a lock nut assembly, Miller 10061. The finished mod is professional both in performance and appearance. It is one of the few mods worth doing to an R-390A.

The 1956 R-390A manual TM 11-856A has a stage gain chart for signal inputs at the balanced antenna input and test points E208 - E211 which is useful for trouble shooting a defective RF subchassis. The stage gain test for signal input at the balanced antenna input is also useful for identifying a defective RF subchassis, and sometimes for other problems. The test involves injecting a signal at the balanced antenna input and for each band determining the signal generator output required to produce -7 VDC at the DIODE LOAD terminal (terminal 14) on the rear panel with R-390A FUNCTION switch set to MGC, BANDWIDTH set to 8, RF gain control fully clockwise, BFO switch OFF, and all other controls in normal operating position. Peak ANT TRIM for each measurement, and tune the signal for maximum voltmeter reading. TM-856A states that with this test setup the signal generator output required to produce -7 VDC at the diode load terminal should be less than 4 microvolts. You should use a precision 50 ohm source signal generator, and the calibration should be checked before doing this test. I use a rebuilt URM-25D which I check with a Tek 453 mod H scope. To check the calibration of a 50 ohm source signal generator, connect the output of the signal generator to a 50 ohm non-inductive resistor, set the output of the signal generator to 100,000 microvolts, and measure the voltage across the resistor. The voltage should be 280 millivolts peak-to-peak. I use a UG-971/U connector (twinax to C) and UG-636A/U (C to BNC) to connect the URM-25D to an R-390A balanced antenna input (through a short length of coax with BNC connectors). The signal generator output required to produce -7 VDC at the DIODE LOAD varies from one R-390A to another. For example, a 1956 Motorola (14-PH-56) required 3.0, 3.5, 2.0, 3.5, 1.0, and 2.0 microvolts at 0.5, 1.5, 7.5, 8.5, 16.5, and 26.5 MHz respectively, while a 1967 EAC (FR-36-etc.) required 2.0, 3.5, 3.5, 2.5, 2.0, and 2.0 microvolts respectively. Another 1967 EAC required 1.0 microvolts at most frequencies, with a few as high as 1.5 microvolts, and a few as low as 0.5 microvolts. There are sometimes variations within a band.

For example, one EAC in the 7 MHz band required 7.0, 3.5, and 6.5 microvolts for -7 VDC at DIODE LOAD at 7.000, 7.500, and 7.999 MHz respectively. On the other hand, the 1956 Motorola required 3.0, 2.0, and 2.0 respectively. I don't know whether this indicates a problem with the EAC in the 7 MHz band, but I am inclined to think not because the EAC 7 MHz band sensitivity was a uniform 0.45 microvolts for a 10 dB S+N/N (AM mode, 4 KHz BW), while the Motorola 7 MHz band sensitivity was a uniform 0.55 microvolts for a 10 dB S+N/N. However, another EAC which required about 4.0 microvolts for -7 VDC at DIODE LOAD at 0.5, 1.5, 7.5, 8.5, 16.5, and 26.5 MHz was defective (a defective LIMITER control which I found by turning the limiter control on and off while doing the DIODE LOAD test). So it is not always trivial to identify a defective R-390A with this test. As a general guideline, if 2.0 microvolts or less is required at several widely spaced frequencies to produce -7 VDC at DIODE LOAD, the R-390A under test is probably OK, while if 3.0 microvolts or more is required at most frequencies, then there may be a problem.

Another useful performance check is to measure the sensitivity for a 10 dB S+N/N ratio. The only equipment you need is a precision signal generator, such as a URM-25D. The R-390A LINE LEVEL meter, LINE METER switch, and LINE GAIN control are used to measure the noise and signal power. Connect the signal generator to the balanced antenna input through a UG-971/U and UG-636A/U as described above, set the BANDWIDTH to 4, BFO to OFF, RF gain control fully clockwise, and all other controls in normal operating position. Set the signal generator to any frequency in the R-390A tuning range, tune the signal generator signal for maximum carrier meter indication (peak ANT TRIM), and reduce the signal generator output to about 0.4 microvolts unmodulated. Set the LINE METER switch to 0 and adjust the LINE GAIN control for a reading of -10 on the LINE LEVEL meter. If no reading is obtained with maximum gain, reduce the LINE GAIN setting, change the LINE METER switch to -10, and adjust the LINE GAIN for a reading of -10 on the LINE LEVEL meter. Change the signal generator to 400 Hz modulation at 50% modulation, and adjust the signal generator output for a reading of VU on the LINE LEVEL meter. The signal generator output is now the 10 dB S+N/N sensitivity (for a URM-25D you will have to switch back to unmodulated CW to read the microvolts output from the 25D meter). An R-390A typically has between 0.4 and 0.5 microvolt sensitivity for a 10 dB S+N/N in AM mode for a 4 KHz BW using this method of measurement. When the sensitivity is measured using an external speaker and voltmeter connected across the speaker, the sensitivity tends to be somewhat better, about 0.3 microvolts. I don't know why. Perhaps the R-390A LINE METER is not as accurate as a precision voltmeter. Or perhaps the voltmeter I have been using to measure R-390A sensitivity is not as accurate as the R-390A LINE METER. In any case, this provides a quick and easy check of R-390A performance, provided the LINE METER circuits are not defective.

As a final performance check, disconnect all antennas, set the FUNCTION switch to AGC, set BANDWIDTH to 8, BFO to OFF, LIMITER to OFF, RF gain fully clockwise, frequency to 5.500 MHz, and all other controls in normal operating position (AUDIO RESPONSE set to WIDE). Adjust ANT TRIM for maximum noise. You should hear a definite increase in noise as you rotate the ANT TRIM. What you are doing is peaking the R-390A front end noise. Set the LINE METER switch to -10 and LINE GAIN control fully clockwise. The LINE LEVEL meter should read no less than UV. Set the LINE METER switch to 0 and LINE GAIN control fully clockwise. The LINE LEVEL meter should read no more than UV.

Similar RF alignment and noise performance checks were published by Charles A. Taylor in his article "R-390A Alignment Chart" in DX News 48, 25 (May 11, 1981), pages 25-28. The other alignment procedures discussed in this article were developed by me and other HSN subscribers.